

TEAM 8

Clarissa Falco
Martina Chudá
Lorenzo Imola
Veronika Syřišťová

ITALY

VENICE - THE THETIS GARDEN

„Don't look away“

INSPIRATIONS | CONCEPT | VISUALIZATION



nest | shelter | wave | Thetis

TECHNICAL ASPECTS

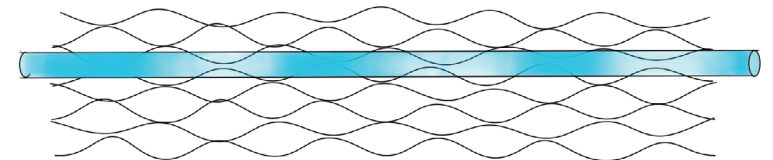
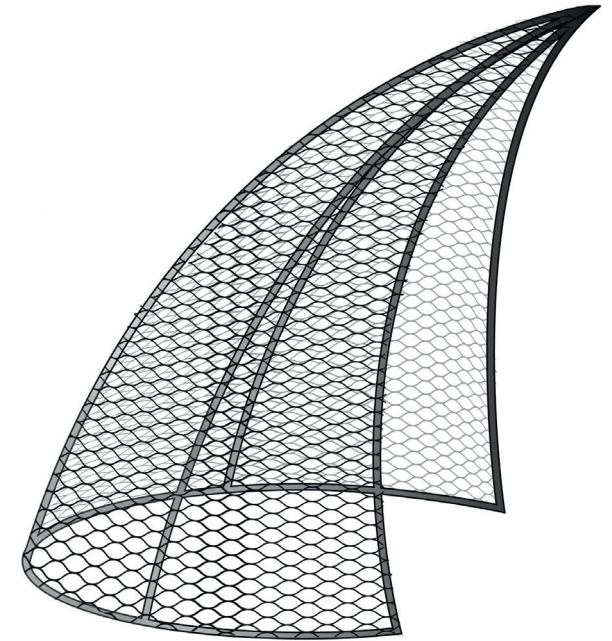
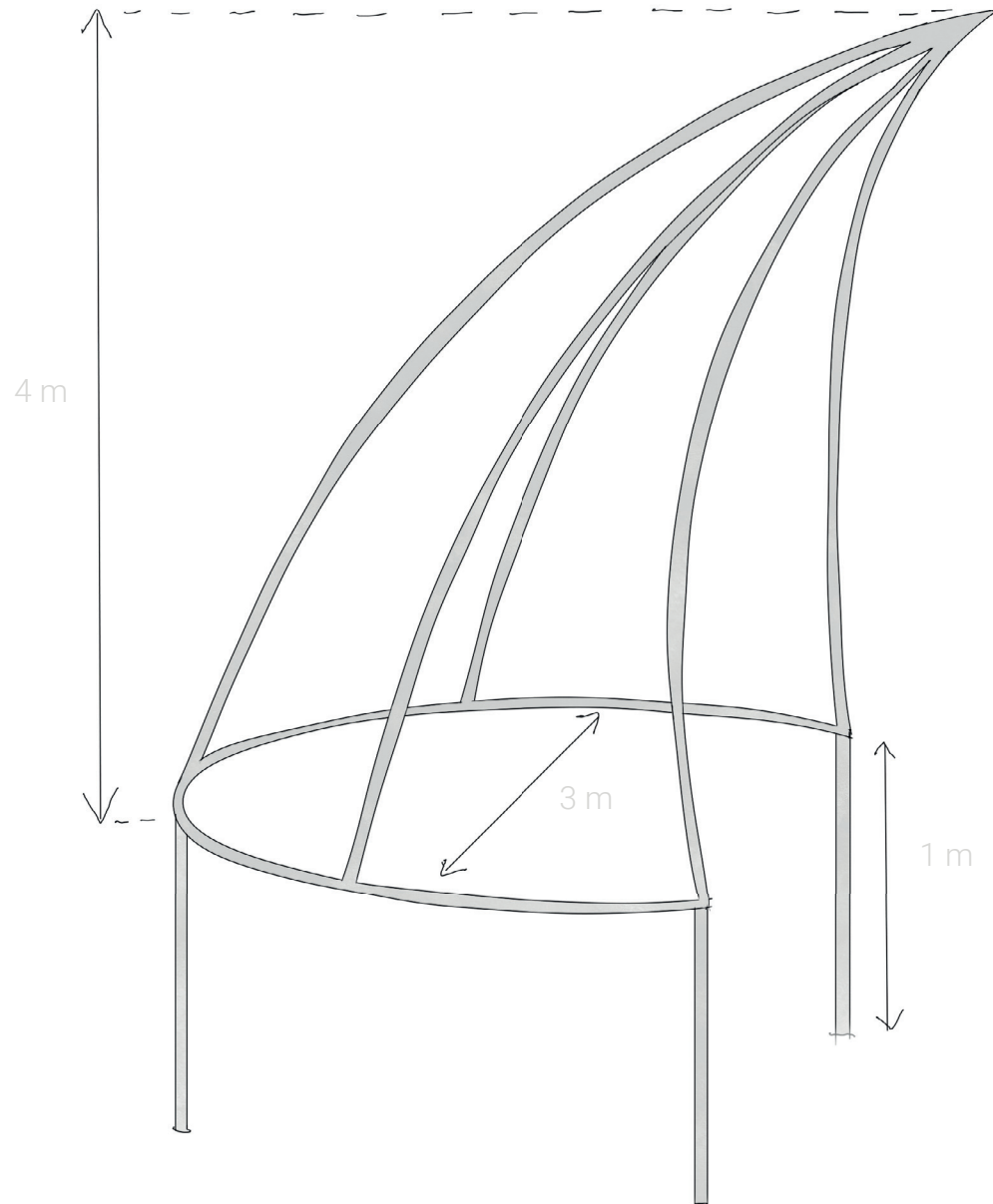

MATERIALS

steel (bamboo) / structure
fishing net / double layer in structure
wooden branches / top layer
moss / top layer
plastic banners / inner layer

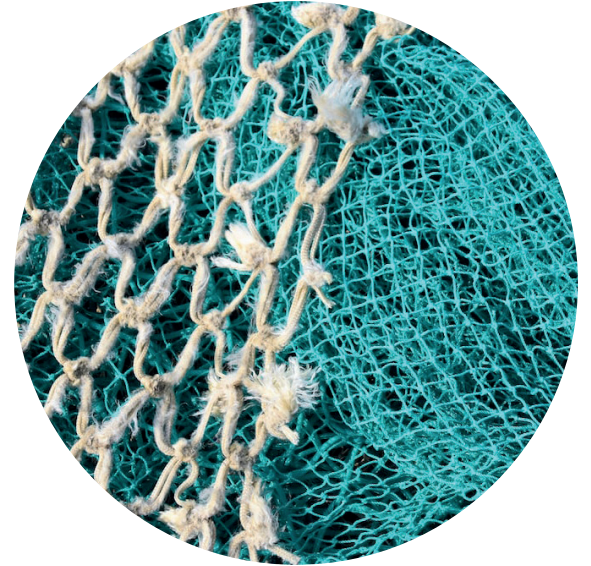

ICELAND
KÓPAVOGUR

„It's nice to be alive again“

INSPIRATIONS | CONCEPT | VISUALIZATION

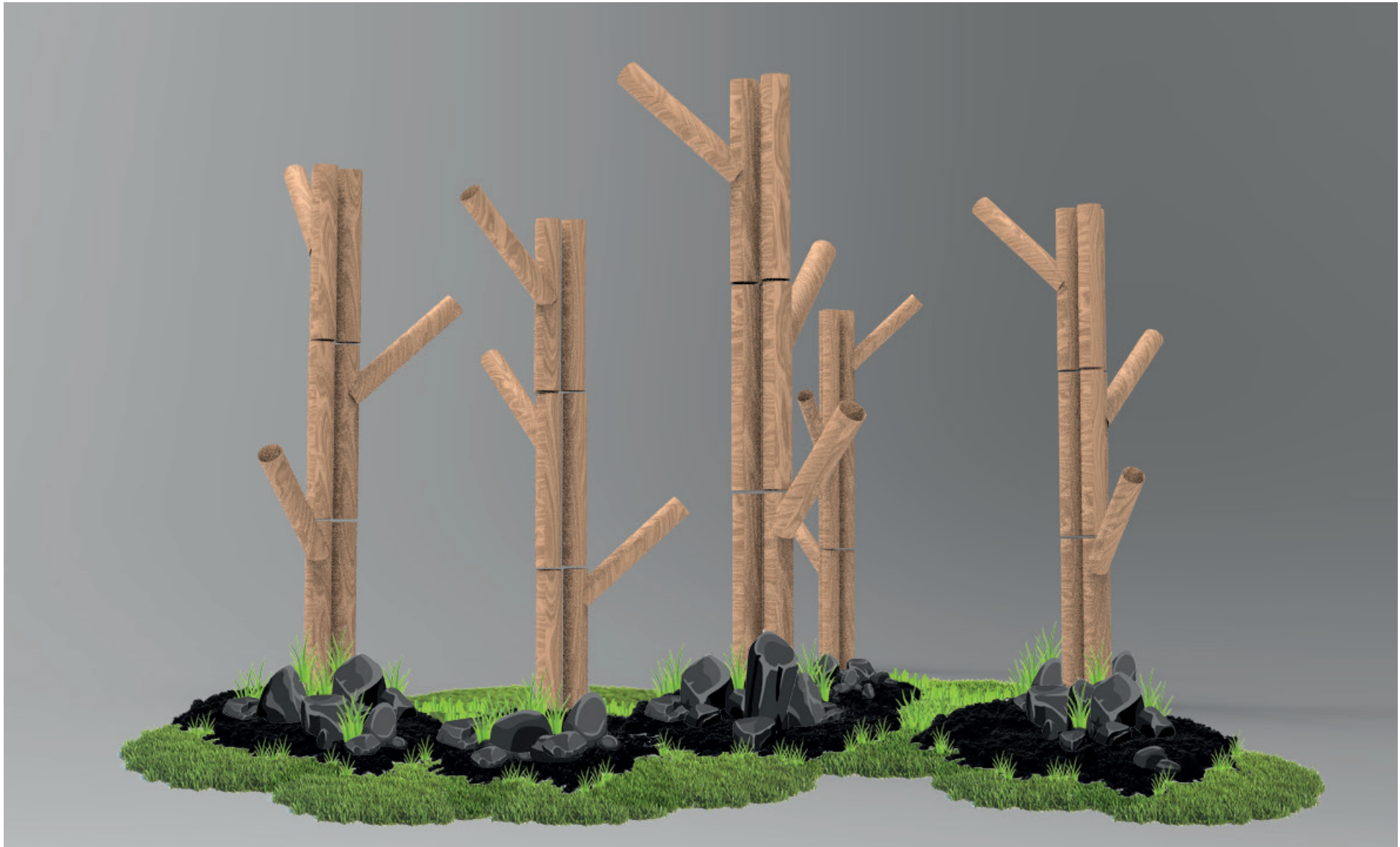

tree | rebirth | landscape | biodiversity

TECHNICAL ASPECTS

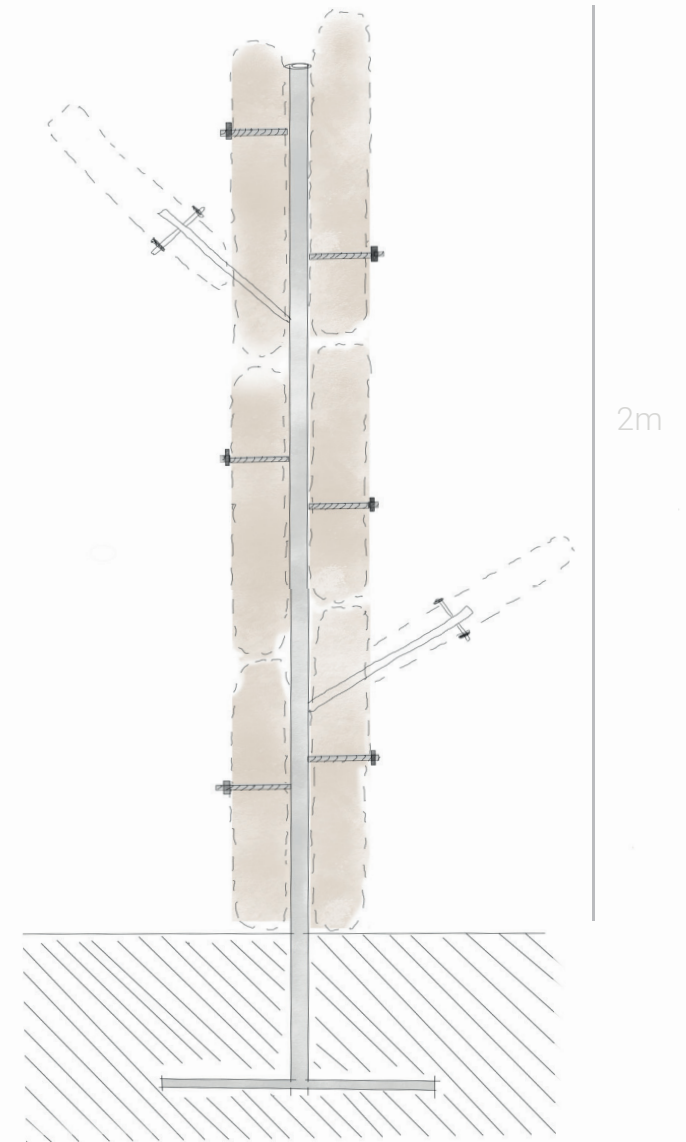

MATERIALS

driftwood / sculpture

black sand / eco concrete basement

hardened lava / basement

steel / structure

threaded rod & nuts / structure



CZECHIA

ÚSTÍ NAD ORLICÍ

„It used to be better - It is going to get better“

INSPIRATIONS | CONCEPT | VISUALIZATION



Perla factory | architecture of the factory | fastfashion
| weaving loom

VISUALIZATIONS

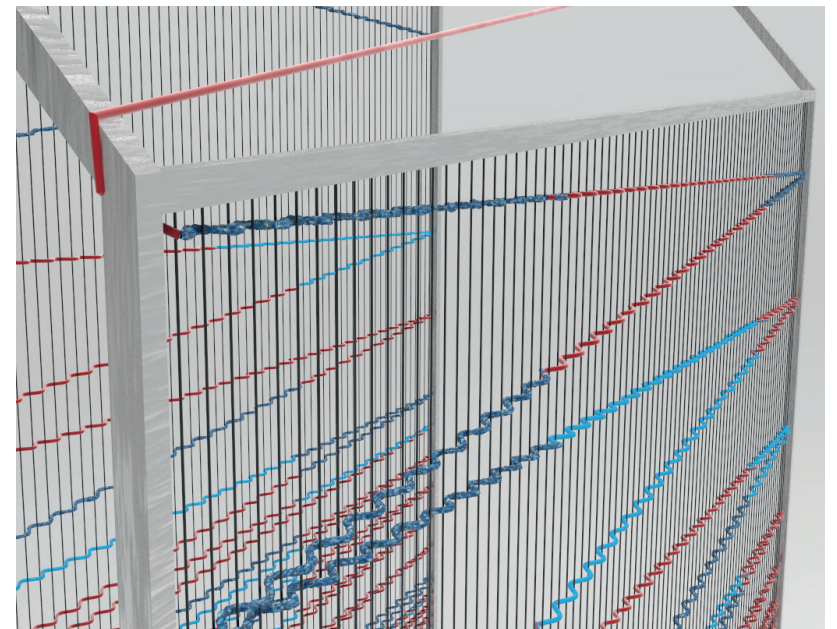
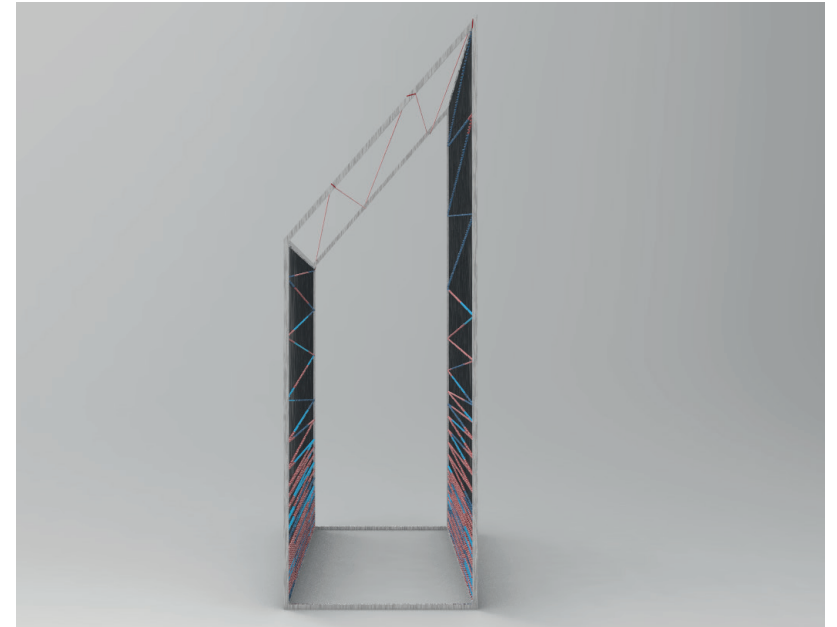
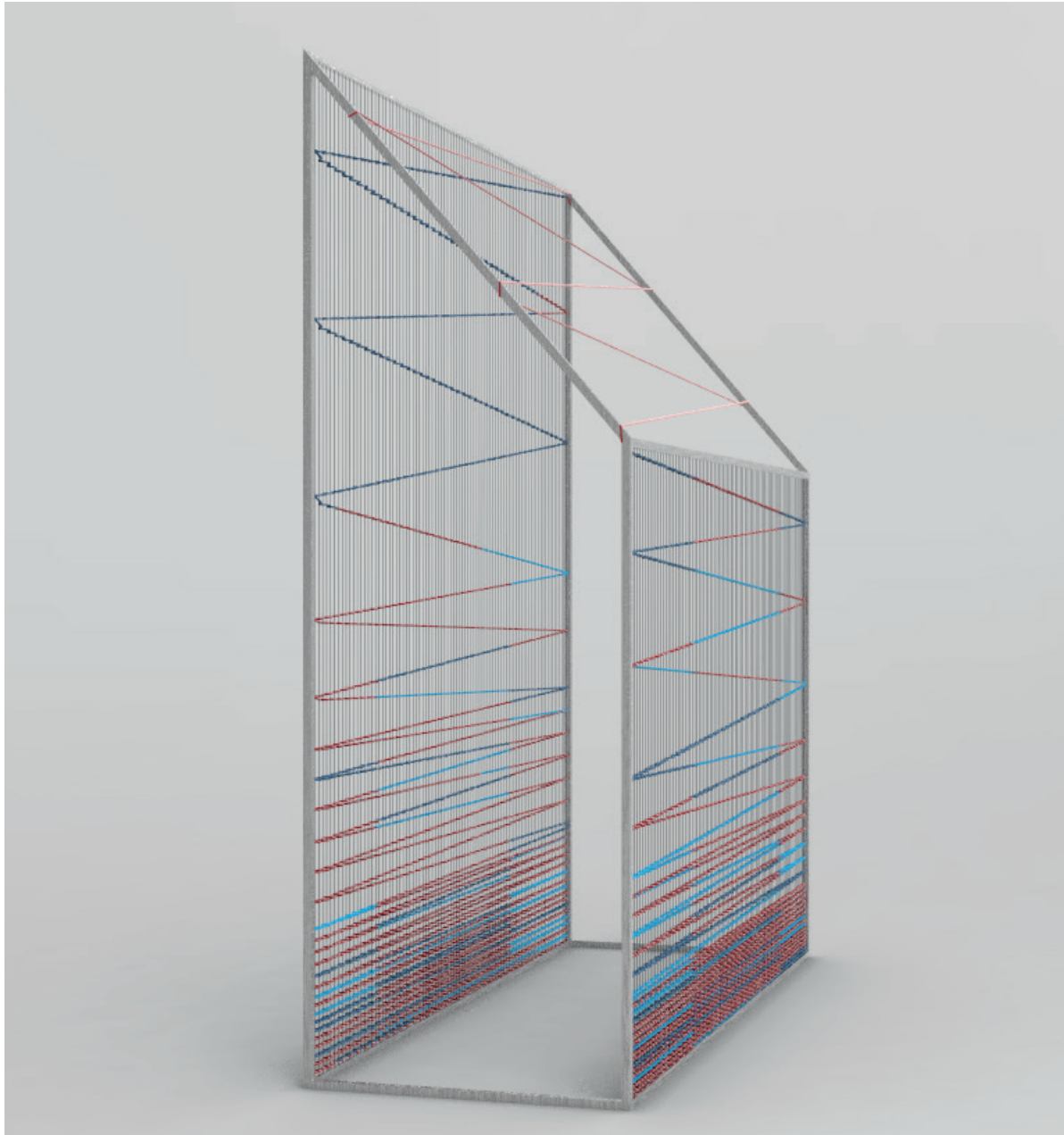

TECHNICAL ASPECTS

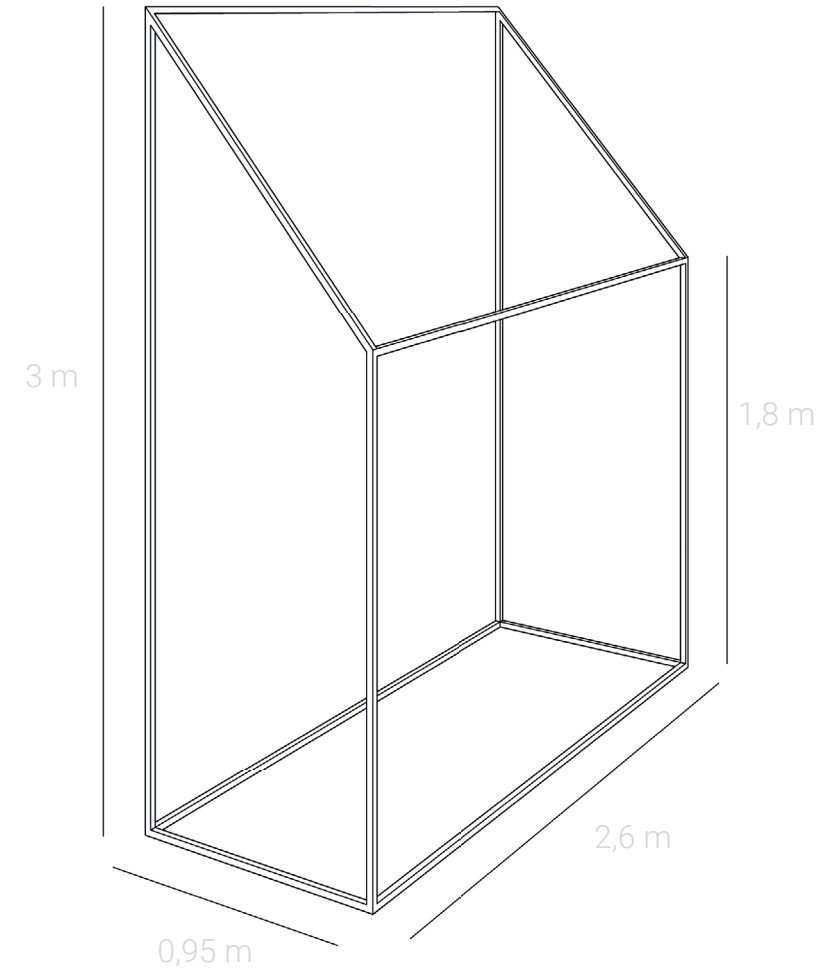

MATERIALS

steel / structure

steel rope / structure

textile waste (stripes) from Tilak
company / weaving into the structure



VENICE



KÓPAVOGUR

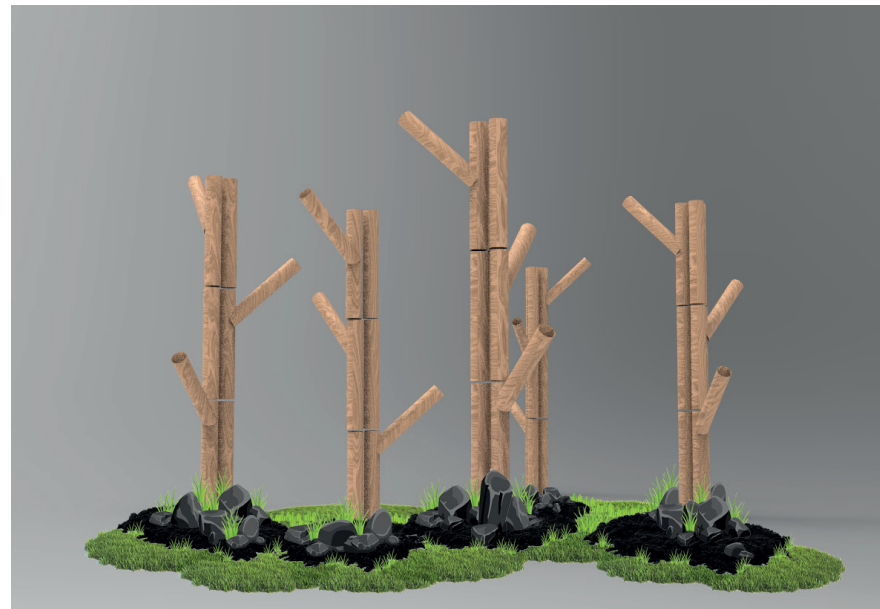

ÚSTÍ NAD ORLICÍ

